

CED 1500



Lancer's **Counter Electric Dispensers (CED)** are designed using the highest quality materials and proven technology providing our customers with consistent drink quality.

Features

- Stainless steel construction exterior and interior
- Available with 4, 5, 6, or 8 post-mix dispensing valves that can be serviced independently
- Insulation is CFC free, 0 GWP, structural foam
- All installation from front of unit
- CFC free, R134A refrigerant
- Flex manifold configuration for multiple non carbonated drinks
- All syrup lines chilled
- LEV® valves standard, other valves available upon request
- Key lock switch
- Lancer™ electronic ice bank control
- 24V secondary transformer
- Available in small, medium and large formats
- External carbonator needed

Accessories and Options

Lighted Marquee

Leg Kit

Certified by these agencies:



CUSTOMER SERVICE

Should you require more information about our products, please do not hesitate to contact our customer service team at custserv@lancerworldwide.com.



WARRANTY

For warranty specifics by product, contact your Lancer™ Sales Representative. Equipment design and/or specifications are subject to change without notice.

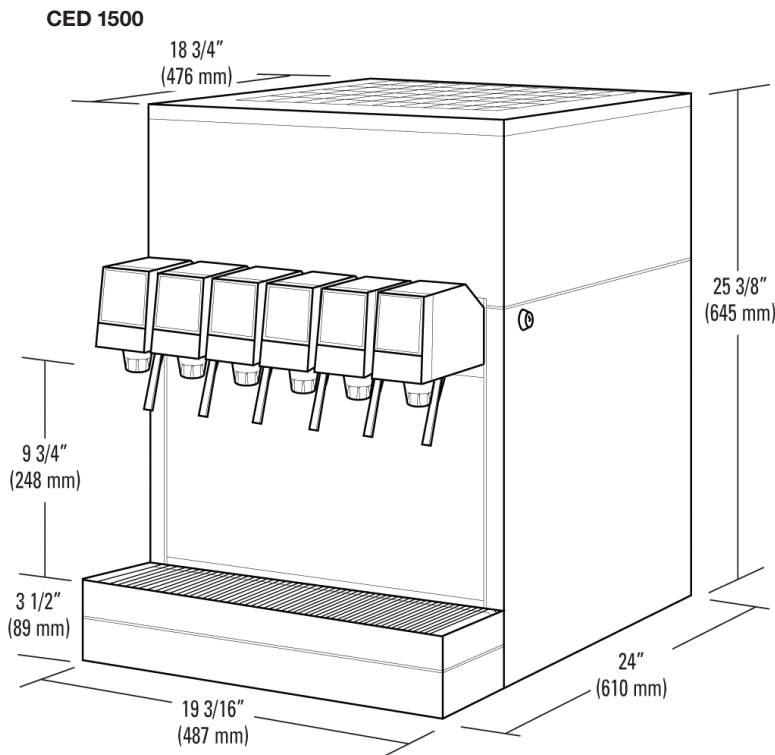

Distinctive Design

All valves are post-mix dispensing and can be serviced independently

- **CED 500** - 4 Valves Flooded 4-0
Split 2-2
- **CED 1500** - 5 valves (2-2-1)
6 valves (3-2-1)
- **CED 1500E** - 5 valves (2-2-1)
6 valves (3-2-1)
- **CED 2500** - 6 valves (3-2-1)
8 valves (3-1-1-3)

Dimensions

CED 500 - 27.5" H x 10.375" W x 25.25" D (699 mm H x 264 mm W x 641 mm D)
 CED 1500 - 25.375" H x 19.187" W x 24" D (645 mm H x 487 mm W x 610 mm D)
 CED 2500 - 31.25" H x 26" W x 27.125" D (794 mm H x 660 mm W x 689 mm D)

Weight

CED 500 - Empty: 89 lbs (40kg) - Operating: 131 lbs (59 kg)
 Shipping: 108 lbs (49 kg)

CED 1500 - Empty: 130 lbs (59 kg) - Operating: 230 lbs (104 kg)
 Shipping: 170 lbs (77 kg)

CED 2500 - Empty: 209 lbs (95 kg) - Operating: 376 lbs (171 kg)
 Shipping: 257 lbs (117 kg)

Ice Bank Weight

CED 500 - 17 lbs (7.7 kg)
 CED 1500 - 30 lbs (13.6 kg)
 CED 2500 - 55 lbs (25 kg)

Water Bath

CED 500 - Capacity: 5 gal (19L)
 CED 1500 - Capacity: 12 gal (45L)
 CED 2500 - Capacity: 21 gal (80 L)

Electrical

CED 500 - 115V/60Hz, 7 Amps - 230V/50Hz, 3.3 Amps
 CED 1500 - 115V/60Hz, 7.8 Amps - 230V/50Hz, 4.5 Amps
 CED 2500 - 115V/60Hz, 12 Amps - 230V/50Hz, 4.3Amps

Compressor

CED 500 - 1/4 hp
 CED 1500 - 1/3 hp
 CED 2500 - 3/4 hp

Motors

CED 500 - Agitator: 15 w - Condenser fan: 9 w
 CED 1500 - Agitator: 25 w - Condenser fan: 9 w
 CED 2500 - Agitator: 25 w - Condenser fan: 35 w

Fittings for all

Syrup inlets: 3/8" (9.5 mm) male barb
 Soda inlets: 3/8" (9.5 mm) male barb

For more information visit lancerworldwide.com or call 1-800-729-1500